



## Liferaft SOLAS OCEANO Throw-overboard Type

**SOLAS/MED - MER APPROVED**



- For use on board commercial vessels engaged on international voyages
- Equipment packs: SOLAS Pack A or SOLAS Pack B
- Available capacities: from 6 to 35 Persons
- Flat pack canister option available (Capacities from 8 to 12 Persons)
- GRP canister
- Durable rubber fabric
- Double chambered tubes
- Stowage height up to 36m (Painter line up to 46m)
- Insulated floor for low temperature conditions
- High visibility canopy with SOLAS reflective tapes
- Fully operational at temperatures from -30°C up to +65°C
- Global Service Stations' network
- Supplied with deck cradle in wooden box (79880-79882 are supplied in wooden box without deck cradle)

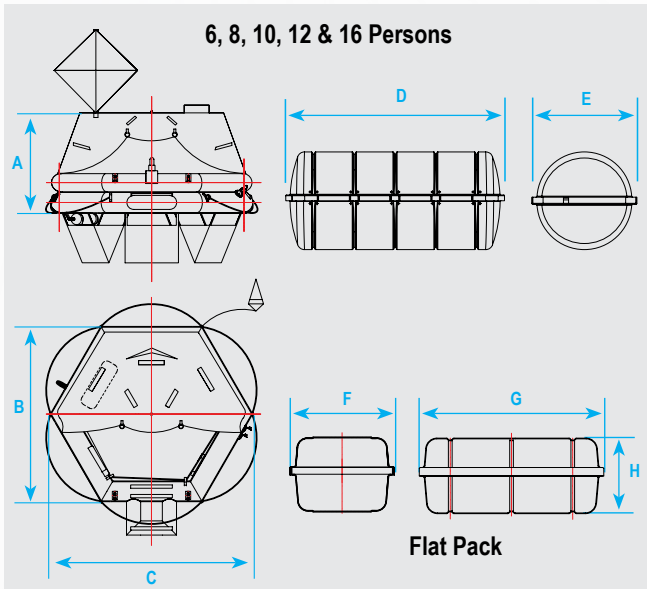

Items included: ✓ Cradle ✓ Operation line

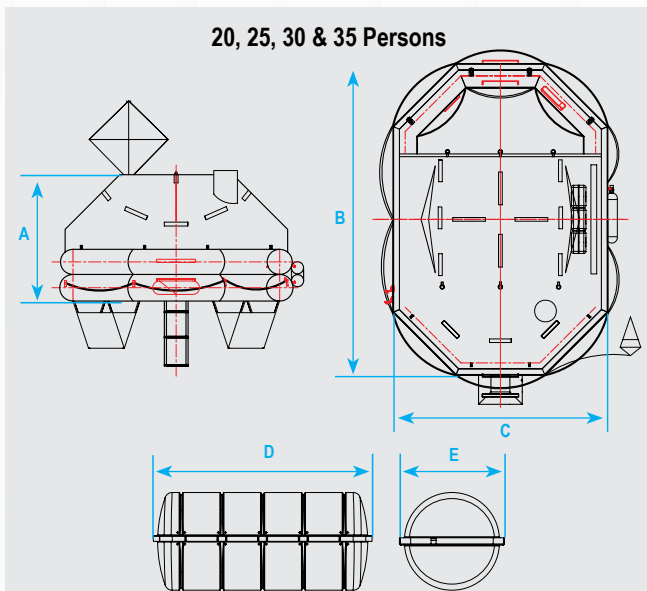

Code	Persons	Weight (kg)*	Pack	Dimensions (mm)							
				A	B	C	D	E	F	G	H
79867	6	76	A	1200	2104	2104	1090	615	-	-	-
79903		66	B				1045	545	-	-	-
79868	8	85	A	1250	2390	2390	1090	615	-	-	-
79880		85	Flat - A				-	-	564	994	405
79904	10	73	B	1400	2694	2694	1045	545	-	-	-
79869		98	A				1230	630	-	-	-
79905	12	82	B	1500	2924	2924	1090	615	-	-	-
79870		108	A				1230	630	-	-	-
79882	15	108	Flat - A	1600	3238	3238	-	-	664	1044	405
79906		92	B				1090	615	-	-	-
79871	16	128	A	1600	3330	3330	1285	670	-	-	-
79907		97	B				1230	645	-	-	-
79872	20	127	A	1600	4304	2974	1285	670	-	-	-
79908		100	B				1335	696	-	-	-
79873	25	149	A	1650	4894	3194	1285	670	-	-	-
79909		120	B				1335	696	-	-	-
79874	30	178	A	1700	5384	3414	1490	757	-	-	-
79910		135	B				1335	696	-	-	-
79875	35	205	A	1750	5899	3568	1700	765	-	-	-
79911		140	B				1490	757	-	-	-
79876		223	A				1700	765	-	-	-
79912		148	B				1490	757	-	-	-

\*Total weight of each liferaft including its canister, without the deck cradle & the wooden box.

## Global Service & Supply Network



- ✓ Global **service network** through owned locations & third-party service providers
- ✓ Global **supply** of **LSA**, **FFE** and **spare parts**
- ✓ Certified quality standards by **major classification societies**
- ✓ **Robust warranty** supported directly by the manufacturer
- ✓ Streamlined **after-sales support** via our ticketing system

*Safety is not just a product, it is an ongoing process!*